

Monolithic IF Amplifier

The MC1350 is an integrated circuit featuring wide range AGC for use as an IF amplifier in radio and TV over an operating temperature range of 0° to +75°C.

- Power Gain: 50 dB Typ at 45 MHz
50 dB Typ at 58 MHz
- AGC Range: 60 dB Min, DC to 45 MHz
- Nearly Constant Input & Output Admittance over the Entire AGC Range
- γ_{21} Constant (-3.0 dB) to 90 MHz
- Low Reverse Transfer Admittance: $<< 1.0 \mu\text{mho}$ Typ
- 12 V Operation, Single-Polarity Power Supply

MAXIMUM RATINGS ($T_A = +25^\circ\text{C}$, unless otherwise noted.)

Rating	Symbol	Value	Unit
Power Supply Voltage	V+	+18	Vdc
Output Supply Voltage	V ₁ , V ₈	+18	Vdc
AGC Supply Voltage	V _{AGC}	V+	Vdc
Differential Input Voltage	V _{in}	5.0	Vdc
Power Dissipation (Package Limitation) Plastic Package Derate above 25°C	P _D	625 5.0	mW mW/°C
Operating Temperature Range	T _A	0 to +75	°C

MC1350

IF AMPLIFIER

SEMICONDUCTOR TECHNICAL DATA

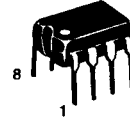

**P SUFFIX
PLASTIC PACKAGE
CASE 626**

**D SUFFIX
PLASTIC PACKAGE
CASE 751
(SO-8)**



ORDERING INFORMATION

Device	Operating Temperature Range	Package
MC1350P	T _A = 0° to +75°C	Plastic DIP
MC1350D		SO-8

Figure 1. Typical MC1350 Video IF Amplifier and MC1330 Low-Level Video Detector Circuit

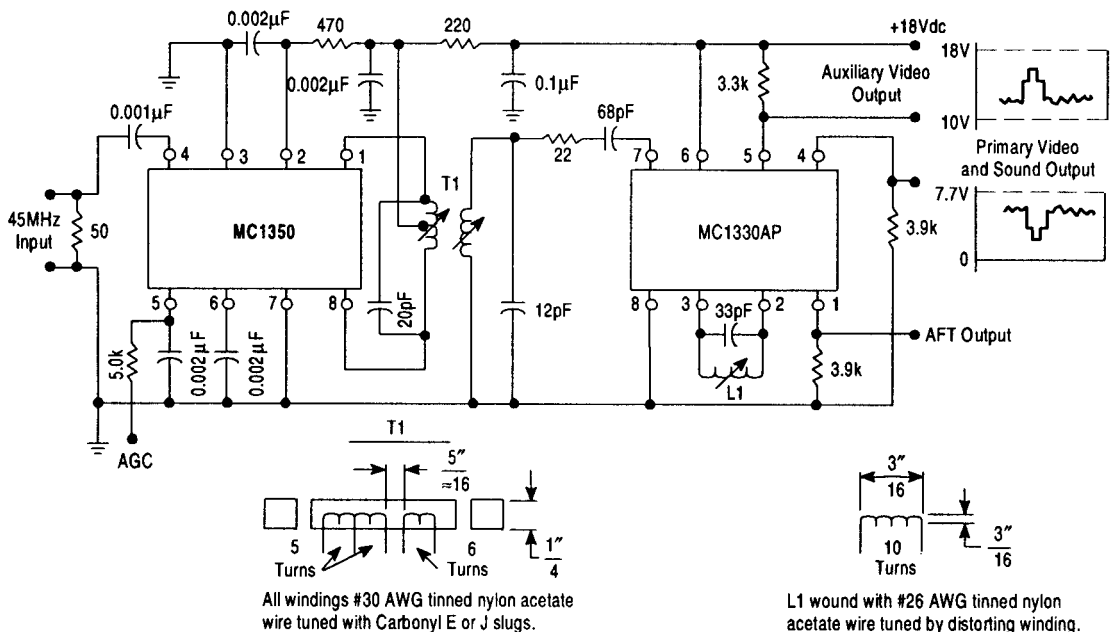

MC1350

ELECTRICAL CHARACTERISTICS ($V^+ = +12$ Vdc, $T_A = +25^\circ\text{C}$, unless otherwise noted.)

Characteristics	Symbol	Min	Typ	Max	Unit
AGC Range, 45 MHz (5.0 V to 7.0 V) (Figure 1)		60	68	-	dB
Power Gain (Pin 5 grounded via a 5.1 k Ω resistor) $f = 58$ MHz, BW = 4.5 MHz See Figure 6(a) $f = 45$ MHz, BW = 4.5 MHz See Figure 6(a), (b) $f = 10.7$ MHz, BW = 350 kHz See Figure 7 $f = 455$ kHz, BW = 20 kHz	A_p	- 46 - -	48 50 58 62	- - - -	dB
Maximum Differential Voltage Swing 0 dB AGC -30 dB AGC	V_O	- -	20 8.0	- -	V_{pp}
Output Stage Current (Pins 1 and 8)	$I_1 + I_8$	-	5.6	-	mA
Total Supply Current (Pins 1, 2 and 8)	I_S	-	14	17	mAdc
Power Dissipation	P_D	-	168	204	mW

DESIGN PARAMETERS, Typical Values ($V^+ = +12$ Vdc, $T_A = +25^\circ\text{C}$, unless otherwise noted.)

Parameter	Symbol	Frequency				Unit
		455 kHz	10.7 MHz	45 MHz	58 MHz	
Single-Ended Input Admittance	g_{11} b_{11}	0.31 0.022	0.36 0.50	0.39 2.30	0.5 2.75	mmho
Input Admittance Variations with AGC (0 dB to 60 dB)	Δg_{11} Δb_{11}	- -	- -	60 0	- -	μmho
Differential Output Admittance	g_{22} b_{22}	4.0 3.0	4.4 110	30 390	60 510	μmho
Output Admittance Variations with AGC (0 dB to 60 dB)	Δg_{22} Δb_{22}	- -	- -	4.0 90	- -	μmho
Reverse Transfer Admittance (Magnitude)	$ y_{12} $	$\ll 1.0$	$\ll 1.0$	$\ll 1.0$	$\ll 1.0$	μmho
Forward Transfer Admittance Magnitude Angle (0 dB AGC) Angle (-30 dB AGC)	$ y_{21} $ $\angle y_{21}$ $\angle y_{21}$	160 -5.0 -3.0	160 -20 -18	200 -80 -69	180 -105 -90	mmho Degrees Degrees
Single-Ended Input Capacitance	C_{in}	7.2	7.2	7.4	7.6	pF
Differential Output Capacitance	C_O	1.2	1.2	1.3	1.6	pF

Figure 2. Typical Gain Reduction

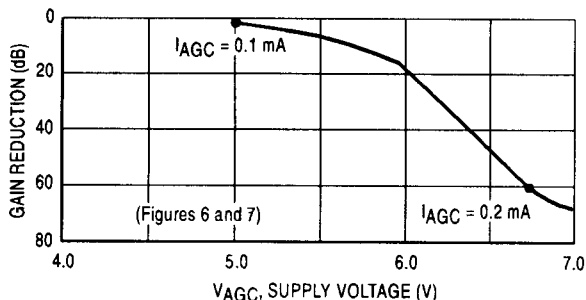
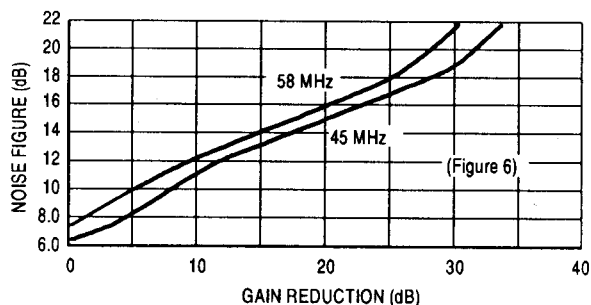

Figure 3. Noise Figure versus Gain Reduction



MC1350

GENERAL OPERATING INFORMATION

The input amplifiers (Q1 and Q2) operate at constant emitter currents so that input impedance remains independent of AGC action. Input signals may be applied single-ended or differentially (for ac) with identical results. Terminals 4 and 6 may be driven from a transformer, but a dc path from either terminal to ground is not permitted.

Figure 4. Circuit Schematic

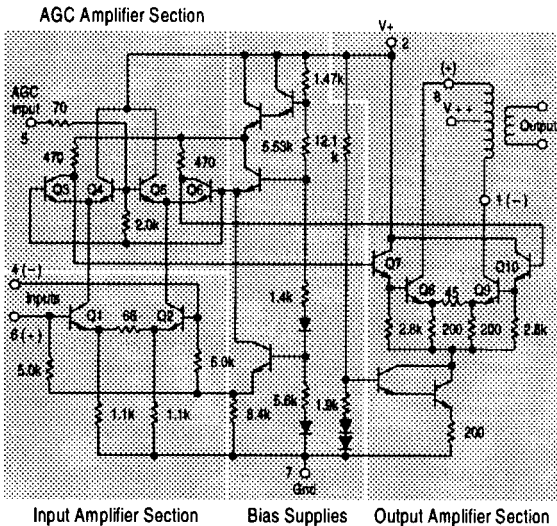

AGC action occurs as a result of an increasing voltage on the base of Q4 and Q5 causing these transistors to conduct more heavily thereby shunting signal current from the interstage amplifiers Q3 and Q6. The output amplifiers are supplied from an active current source to maintain constant quiescent bias thereby holding output admittance nearly constant. Collector voltage for the output amplifier must be supplied through a center-tapped tuning coil to Pins 1 and 8. The 12 V supply (V^+) at Pin 2 may be used for this purpose, but output admittance remains more nearly constant if a separate 15 V supply ($V^+ +$) is used, because the base voltage on the output amplifier varies with AGC bias.

Figure 5. Frequency Response Curve (45 MHz and 58 MHz)

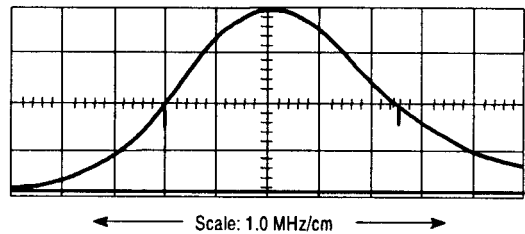
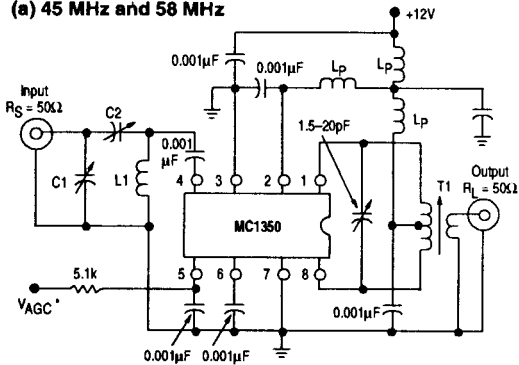
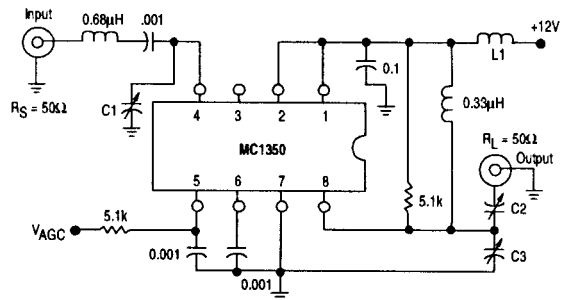

Figure 6. Power Gain, AGC and Noise Figure Test Circuits

(a) 45 MHz and 58 MHz



(b) Alternate 45 MHz



*Connect to ground for maximum power gain test.

All power supply chokes (L_p), are self-resonant at input frequency. $L_p \geq 20 \text{ k}\Omega$.
See Figure 5 for Frequency Response Curve.

L1 @ 45 MHz = 7 1/4 Turns on a 1/4" coil form

@ 58 MHz = 6 Turns on a 1/4" coil form

T1 Primary Winding = 18 Turns on a 1/4" coil form, center-tapped, #25 AWG

Secondary Winding = 2 Turns centered over Primary Winding @ 45 MHz

= 1 Turn @ 58 MHz

Slug = Carbonyl E or J

L1	Ferrite Core 14 Turns 28 S.W.G.
C1	5-25 pF
C2	5-25 pF
C3	5-25 pF

	45 MHz		58 MHz	
L1	0.4 μH	$Q \geq 100$	0.3 μH	$Q \geq 100$
T1	1.3 μH to 3.4 μH	$Q \geq 100$ @ 2.0 μH	1.2 μH to 3.8 μH	$Q \geq 100$ @ 2.0 μH
C1	50 pF to 160 pF		8.0 pF to 60 pF	
C2	8.0 pF to 60 pF		3.0 pF to 35 pF	

MC1350

Figure 7. Power Gain and AGC Test Circuit
(455 kHz and 10.7 MHz)

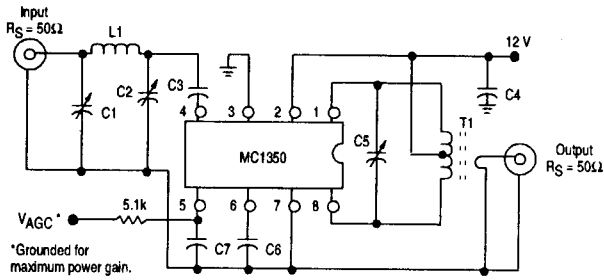

Component	Frequency	
	455 kHz	10.7 MHz
C1	—	80–450 pF
C2	—	5.0–80 pF
C3	0.05 μ F	0.001 μ F
C4	0.05 μ F	0.05 μ F
C5	0.001 μ F	36 pF
C6	0.05 μ F	0.05 μ F
C7	0.05 μ F	0.05 μ F
L1	—	4.6 μ H
T1	Note 1	Note 2

NOTES: 1. Primary: 120 μ H (center-tapped)
 $Q_U = 140$ at 455 kHz
 Primary: Secondary turns ratio ≈ 13

2. Primary: 6.0 μ H
 Primary winding = 24 turns #36 AWG
 (close-wound on 1/4" dia. form)
 Core = Carbonyl E or J
 Secondary winding = 1–1/2 turns #36 AWG, 1/4" dia.
 (wound over center-tap)

Figure 8. Single-Ended Input Admittance

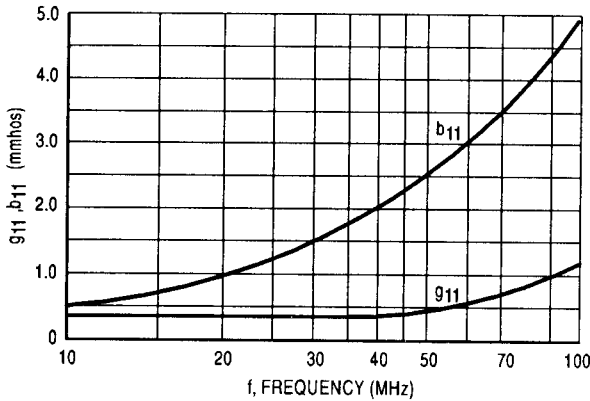

Figure 9. Forward Transfer Admittance

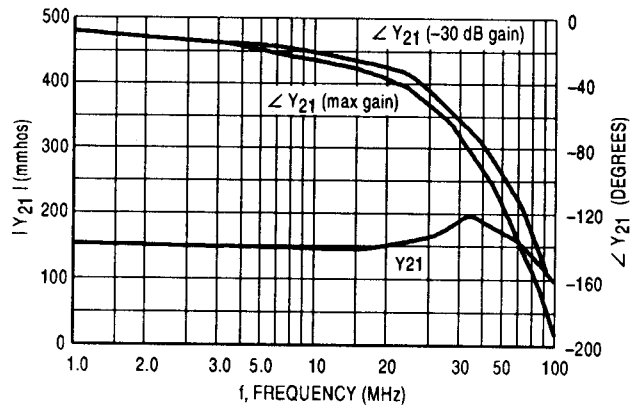

Figure 10. Differential Output Admittance

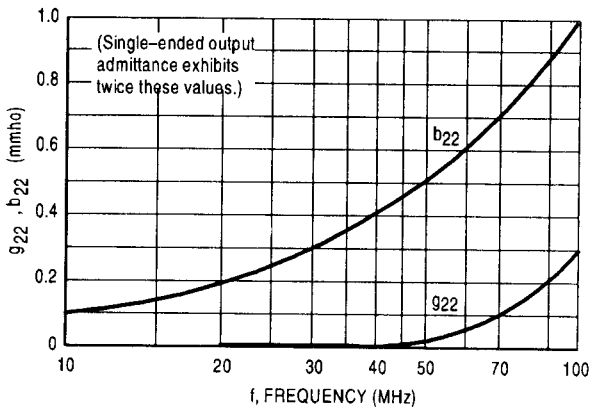

Figure 11. Differential Output Voltage

